

S10, S15 & S20 Snack Master Small



Belt extension for easy loading



Individual temperature and speed controls

The Snack Master Small is sized to fit on any benchtop, allowing for perfect toasting.

This super-efficient, easy loading compact conveyor is complete with belt extension for easy loading, individual controls for temperature adjustments and features turbo fan cooling.

Toasting has never been easier.



FEATURES & BENEFITS

- 305mm belt width conveyor oven, ideal for toasting/cooking open snacks
- Smallest footprint of the Snackmaster range
- Available in either 10/15/20 Amp models
- Long life metal incaloy elements for continuous use
- Long cooking conveyor for easy loading
- Fan cooled controls and fan forced heat technology
- Independent temperature controls for top and bottom elements
- Variable speed belt control with automatic tensioning
- Stainless steel construction
- All models supplied with suitable plug and lead

W.CVS.S.xxx

SPECIFICATIONS

10 / 15 / 20

kW 2.4 / 3.6 / 4.8 **Amps** 10 / 15 / 20

Width 900mm **Depth** 445mm

Height 465mm

Oven Chamber Width 315mm

Oven Chamber Length 430mm

Oven Head Clearance 90mm

Dealer:

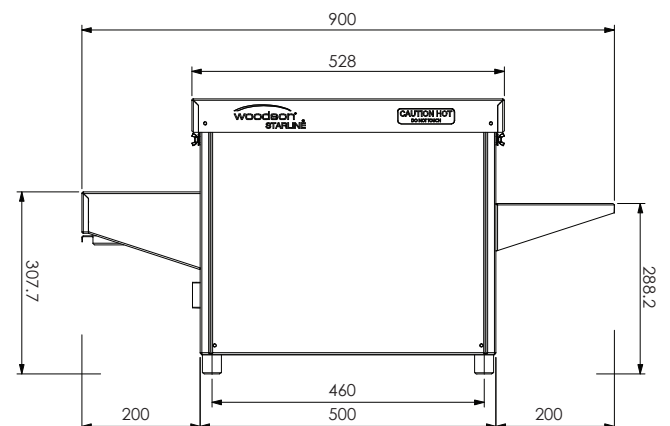
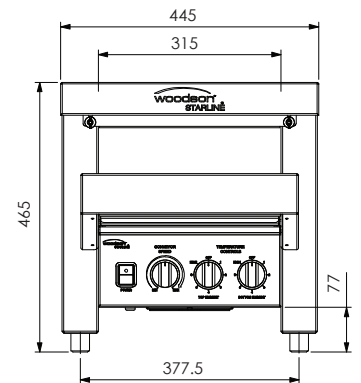

We reserve the right to alter specifications of products without notice. All dimensions are in mm.