

S30 Snack Master Large



Long conveyor belt for easy loading



Touch pad "set and forget" control panel

Starline's largest compact unit, the Snackmaster 30, is designed to suit any bench space providing a durable, functional and accessible cooking environment.

With a longer and wider cooking chamber, this unit effortlessly increases output and results in a more efficient commercial kitchen.



W.CVS.L.30

FEATURES & BENEFITS

- 450mm belt width conveyor oven, ideal for toasting/cooking open snacks
- Largest size of the snackmaster range
- Available in 30 Amp model
- Long life metal elements for continuous use
- Long cooking conveyor for easy loading
- Touchpad "set and forget" control system
- Fan cooled controls and fan forced heat technology
- Energy efficient pulse power independent temperature controls for top and bottom elements
- Variable speed belt control with automatic tensioning
- Stainless steel construction
- Chamber dimensions of 480mm wide, 600mm long, with an 85mm clearance
- Supplied with 2 metre lead for hard wiring on site by a qualified electrician. Optional factory fitted plug is available, see below*
- Units configured for right to left conveyor operation as standard. Left to right operation can be selected at time of order by adding an "L" to end of the model number.
- *Optional factory fitted single phase 32 Amp 3 round pin plug (must be selected at time of order)

SPECIFICATIONS

kW 7.2 **Amps** 30
Width 1200mm **Depth** 610mm
Height 465mm
Oven Chamber Width 480mm
Oven Chamber Length 600mm
Oven Head Clearance 90mm

Dealer:

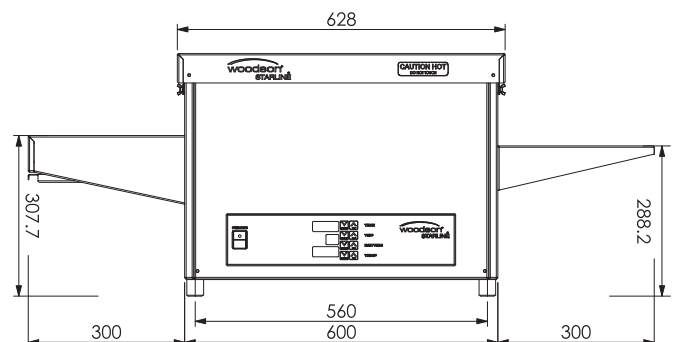
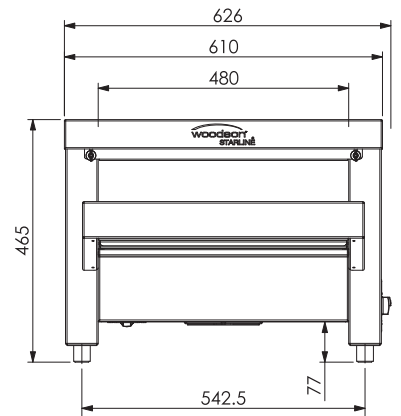

We reserve the right to alter specifications of products without notice. All dimensions are in mm.

www.stoddart.com.au